



**EN**

welding torch

TIG 150 F1 GD 5P  
TIG 150 F1 GD U/D 8P

099-518351-EW501

Observe additional system documents!

07.06.2023

**Register now  
and benefit!  
Jetzt Registrieren  
und Profitieren!**

[www.ewm-group.com](http://www.ewm-group.com)



# General instructions

## WARNING



### **Read the operating instructions!**

#### **The operating instructions provide an introduction to the safe use of the products.**

- Read and observe the operating instructions for all system components, especially the safety instructions and warning notices!
- Observe the accident prevention regulations and any regional regulations!
- The operating instructions must be kept at the location where the machine is operated.
- Safety and warning labels on the machine indicate any possible risks. Keep these labels clean and legible at all times.
- The machine has been constructed to state-of-the-art standards in line with any applicable regulations and industrial standards. Only trained personnel may operate, service and repair the machine.
- Technical changes due to further development in machine technology may lead to a differing welding behaviour.

**In the event of queries on installation, commissioning, operation or special conditions at the installation site, or on usage, please contact your sales partner or our customer service department on +49 2680 181-0.**

**A list of authorised sales partners can be found at [www.ewm-group.com/en/specialist-dealers](http://www.ewm-group.com/en/specialist-dealers).**

Liability relating to the operation of this equipment is restricted solely to the function of the equipment. No other form of liability, regardless of type, shall be accepted. This exclusion of liability shall be deemed accepted by the user on commissioning the equipment.

The manufacturer is unable to monitor whether or not these instructions or the conditions and methods are observed during installation, operation, usage and maintenance of the equipment.

An incorrectly performed installation can result in material damage and injure persons as a result. For this reason, we do not accept any responsibility or liability for losses, damages or costs arising from incorrect installation, improper operation or incorrect usage and maintenance or any actions connected to this in any way.

© EWM GmbH

Dr. Günter-Henle-Strasse 8  
56271 Mündersbach Germany  
Tel.: +49 2680 181-0, Fax: -244  
Email: [info@ewm-group.com](mailto:info@ewm-group.com)

**[www.ewm-group.com](http://www.ewm-group.com)**

The copyright to this document remains the property of the manufacturer.

Copying, including extracts, only permitted with written approval.

The content of this document has been prepared and reviewed with all reasonable care. The information provided is subject to change; errors excepted.

### **Data security**

The user is responsible for backing up data of all changes from the factory setting. The user is liable for erased personal settings. The manufacturer does not assume any liability for this.

## 1

**Contents**

<b>1</b>	<b>Contents</b> .....	<b>3</b>
<b>2</b>	<b>For your safety</b> .....	<b>5</b>
2.1	Notes on using these operating instructions .....	5
2.2	Explanation of icons .....	6
2.3	Safety instructions.....	7
2.4	Transport and installation .....	10
<b>3</b>	<b>Intended use</b> .....	<b>12</b>
3.1	Applications.....	12
3.2	Documents which also apply.....	12
3.2.1	Warranty .....	12
3.2.2	Declaration of Conformity .....	12
3.2.3	Service documents (spare parts) .....	12
3.2.4	Part of the complete documentation .....	13
<b>4</b>	<b>Product description – quick reference</b> .....	<b>14</b>
4.1	Product variants .....	14
4.2	Welding fume extractor .....	15
4.2.1	TIG 150 F1 GD .....	15
4.2.1.1	Connection variants .....	16
<b>5</b>	<b>Design and function</b> .....	<b>18</b>
5.1	General .....	18
5.2	Scope of delivery.....	19
5.3	Transport and installation .....	19
5.3.1	Ambient conditions.....	19
5.4	Wear part replacement.....	20
5.4.1	Deinstallation/Installation .....	20
5.4.2	Electrode replacement .....	21
5.4.2.1	Regrinding the electrode.....	21
5.4.2.2	Setting the electrode spacing .....	22
5.5	Function specification.....	23
5.5.1	General .....	23
5.5.2	Operating elements.....	23
5.5.2.1	Standard TIG torch (5-pole).....	23
5.5.2.2	TIG Up/Down torch .....	23
<b>6</b>	<b>Commissioning</b> .....	<b>25</b>
6.1	Hose package connection .....	25
6.2	Welding fume extractor .....	25
<b>7</b>	<b>Maintenance, care and disposal</b> .....	<b>26</b>
7.1	General .....	26
7.1.1	Identifying damage or worn components .....	26
7.1.2	Improper use.....	27
7.1.3	Maintenance and care before each use .....	28
7.1.4	Regular maintenance.....	28
7.1.5	Extraction unit .....	28
7.2	Disposing of equipment.....	29
<b>8</b>	<b>Rectifying faults</b> .....	<b>30</b>
8.1	Checklist for rectifying faults.....	30
<b>9</b>	<b>Technical data</b> .....	<b>32</b>
9.1	TIG 150 F1 GD.....	32
9.1.1	Definition of terms .....	33
<b>10</b>	<b>Accessories</b> .....	<b>34</b>
10.1	List of tools.....	34
10.2	Options.....	34
<b>11</b>	<b>Replaceable parts</b> .....	<b>35</b>
11.1	TIG 150 F1 GD.....	35
<b>12</b>	<b>Service documents</b> .....	<b>36</b>
12.1	Circuit diagram .....	36

---

12.1.1	Standard, up/down torches .....	36
<b>13</b>	<b>Appendix .....</b>	<b>37</b>
13.1	Altitude alignment.....	37
13.2	Searching for a dealer.....	38

## 2 For your safety

### 2.1 Notes on using these operating instructions

#### **DANGER**

**Working or operating procedures which must be closely observed to prevent imminent serious and even fatal injuries.**

- Safety notes include the "DANGER" keyword in the heading with a general warning symbol.
- The hazard is also highlighted using a symbol on the edge of the page.

#### **WARNING**

**Working or operating procedures which must be closely observed to prevent serious and even fatal injuries.**

- Safety notes include the "WARNING" keyword in the heading with a general warning symbol.
- The hazard is also highlighted using a symbol in the page margin.

#### **CAUTION**

**Working or operating procedures which must be closely observed to prevent possible minor personal injury.**

- The safety information includes the "CAUTION" keyword in its heading with a general warning symbol.
- The risk is explained using a symbol on the edge of the page.



**Technical aspects which the user must observe to avoid material or equipment damage.**

Instructions and lists detailing step-by-step actions for given situations can be recognised via bullet points, e.g.:

- Insert the welding current lead socket into the relevant socket and lock.

## 2.2 Explanation of icons

Symbol	Description	Symbol	Description
	Indicates technical aspects which the user must observe.		Activate and release / Tap / Tip
	Switch off machine		Release
	Switch on machine		Press and hold
	Incorrect / Invalid		Switch
	Correct / Valid		Turn
	Input		Numerical value – adjustable
	Navigation		Signal light lights up in green
	Output		Signal light flashes green
	Time representation (e.g.: wait 4 s / actuate)		Signal light lights up in red
	Interruption in the menu display (other setting options possible)		Signal light flashes red
	Tool not required/do not use		Signal light lights up in blue
	Tool required/use		Signal light flashes blue

## 2.3 Safety instructions

### WARNING



**Risk of accidents due to non-compliance with the safety instructions!**  
**Non-compliance with the safety instructions can be fatal!**

- Carefully read the safety instructions in this manual!
- Observe the accident prevention regulations and any regional regulations!
- Inform persons in the working area that they must comply with the regulations!



**Risk of injury from electrical voltage!**

**Voltages can cause potentially fatal electric shocks and burns on contact. Even low voltages can cause a shock and lead to accidents.**

- Never touch live components such as welding current sockets or stick, tungsten or wire electrodes!
- Always place torches and electrode holders on an insulated surface!
- Wear the full personal protective equipment (depending on the application)!
- The machine may only be opened by qualified personnel!
- The device must not be used to defrost pipes!



**Hazard when interconnecting multiple power sources!**

**If a number of power sources are to be connected in parallel or in series, only a technical specialist may interconnect the sources as per standard IEC 60974-9:2010: Installation and use and German Accident Prevention Regulation BVG D1 (formerly VBG 15) or country-specific regulations.**

**Before commencing arc welding, a test must verify that the equipment cannot exceed the maximum permitted open circuit voltage.**

- Only qualified personnel may connect the machine.
- When taking individual power sources out of operation, all mains and welding current leads must be safely disconnected from the welding system as a whole. (Hazard due to reverse polarity voltage!)
- Do not interconnect welding machines with pole reversing switch (PWS series) or machines for AC welding since a minor error in operation can cause the welding voltages to be combined, which is not permitted.



**Risk of injury due to radiation or heat!**

**Arc radiation can lead to skin and eye injuries.**

**Contact with hot workpieces and sparks can lead to burns.**

- Use hand shield or welding helmet with the appropriate safety level (depends on the application).
- Wear dry protective clothing (e.g. hand shield, gloves, etc.) in accordance with the applicable regulations of your country.
- Persons who are not directly involved should be protected with a welding curtain or suitable safety screen against radiation and the risk of blinding!

## **WARNING**



### **Risk of injury due to improper clothing!**

**During arc welding, radiation, heat and voltage are sources of risk that cannot be avoided. The user has to be equipped with the complete personal protective equipment at all times. The protective equipment has to include:**

- Respiratory protection against hazardous substances and mixtures (fumes and vapours); otherwise implement suitable measures such as extraction facilities.
- Welding helmet with proper protection against ionizing radiation (IR and UV radiation) and heat.
- Dry welding clothing (shoes, gloves and body protection) to protect against warm environments with conditions comparable to ambient temperatures of 100 °C or higher and arcing and work on live components.
- Hearing protection against harming noise.



### **Explosion risk!**

**Apparently harmless substances in closed containers may generate excessive pressure when heated.**

- Move containers with inflammable or explosive liquids away from the working area!
- Never heat explosive liquids, dusts or gases by welding or cutting!



### **Fire hazard!**

**Due to the high temperatures, sparks, glowing parts and hot slag that occur during welding, there is a risk of flames.**

- Be watchful of potential sources of fire in the working area!
- Do not carry any easily inflammable objects, e.g. matches or lighters.
- Ensure suitable fire extinguishers are available in the working area!
- Thoroughly remove any residue of flammable materials from the workpiece prior to starting to weld.
- Only further process workpieces after they have cooled down. Do not allow them to contact any flammable materials!



**⚠ CAUTION****Smoke and gases!**

**Smoke and gases may lead to shortness of breath and poisoning! The ultraviolet radiation of the arc may also convert solvent vapours (chlorinated hydrocarbon) into poisonous phosgene.**

- Ensure sufficient fresh air!
- Keep solvent vapours away from the arc beam field!
- Wear suitable respiratory protection if necessary!
- To prevent the formation of phosgene, residues of chlorinated solvents on workpieces must first be neutralised using appropriate measures.

**Noise exposure!**

**Noise exceeding 70 dBA can cause permanent hearing damage!**

- Wear suitable ear protection!
- Persons located within the working area must wear suitable ear protection!



**According to IEC 60974-10, welding machines are divided into two classes of electromagnetic compatibility (the EMC class can be found in the Technical data) > see 9 chapter:**



**Class A** machines are not intended for use in residential areas where the power supply comes from the low-voltage public mains network. When ensuring the electromagnetic compatibility of class A machines, difficulties can arise in these areas due to interference not only in the supply lines but also in the form of radiated interference.



**Class B** machines fulfil the EMC requirements in industrial as well as residential areas, including residential areas connected to the low-voltage public mains network.

**Setting up and operating**

When operating arc welding systems, in some cases, electro-magnetic interference can occur although all of the welding machines comply with the emission limits specified in the standard. The user is responsible for any interference caused by welding.

In order to **evaluate** any possible problems with electromagnetic compatibility in the surrounding area, the user must consider the following: (see also EN 60974-10 Appendix A)

- Mains, control, signal and telecommunication lines
- Radios and televisions
- Computers and other control systems
- Safety equipment
- The health of neighbouring persons, especially if they have a pacemaker or wear a hearing aid
- Calibration and measuring equipment
- The immunity to interference of other equipment in the surrounding area
- The time of day at which the welding work must be carried out

**Recommendations for reducing interference emission**

- Mains connection, e.g. additional mains filter or shielding with a metal tube
- Maintenance of the arc welding system
- Welding leads should be as short as possible and run closely together along the ground
- Potential equalization
- Earthing of the workpiece. In cases where it is not possible to earth the workpiece directly, it should be connected by means of suitable capacitors.
- Shielding from other equipment in the surrounding area or the entire welding system

**Electromagnetic fields!**

**The power source can create electrical or electromagnetic fields that may impair the function of electronic systems such as EDP and CNC devices, telecommunication, power and signal lines as well as pacemakers and defibrillators.**



- Follow the maintenance instructions > see 7 chapter!
- Unwind the welding leads completely!
- Shield radiation-sensitive equipment or facilities appropriately!
- The function of pacemakers may be impaired (seek medical advice if necessary).

## CAUTION



### Obligations of the operator!

**The respective national directives and laws must be complied with when operating the machine!**

- Implementation of national legislation relating to framework directive 89/391/EEC on the introduction of measures to encourage improvements in the safety and health of workers at work and associated individual guidelines.
- In particular, directive 89/655/EEC concerning the minimum safety and health requirements for the use of work equipment by workers at work.
- The regulations applicable to occupational safety and accident prevention in the country concerned.
- Setting up and operating the machine as per IEC 60974.-9.
- Brief the user on safety-conscious work practices on a regular basis.
- Regularly inspect the machine as per IEC 60974.-4.



***The manufacturer's warranty becomes void if non-genuine parts are used!***

- ***Only use system components and options (power sources, welding torches, electrode holders, remote controls, spare parts and replacement parts, etc.) from our range of products!***
- ***Only insert and lock accessory components into the relevant connection socket when the machine is switched off.***

### Requirements for connection to the public mains network

High-performance machines can influence the mains quality by taking current from the mains network. For some types of machines, connection restrictions or requirements relating to the maximum possible line impedance or the necessary minimum supply capacity at the interface with the public network (Point of Common Coupling, PCC) can therefore apply. In this respect, attention is also drawn to the machines' technical data. In this case, it is the responsibility of the operator, where necessary in consultation with the mains network operator, to ensure that the machine can be connected.

## 2.4 Transport and installation

## WARNING



### Risk of injury due to improper handling of shielding gas cylinders!

**Improper handling and insufficient securing of shielding gas cylinders can cause serious injuries!**

- Observe the instructions from the gas manufacturer and any relevant regulations concerning the use of compressed air!
- Do not attach any element to the shielding gas cylinder valve!
- Prevent the shielding gas cylinder from heating up.

**⚠ CAUTION****Risk of accidents due to supply lines!**

During transport, attached supply lines (mains leads, control cables, etc.) can cause risks, e.g. by causing connected machines to tip over and injure persons!

- Disconnect all supply lines before transport!

**Risk of tipping!**

There is a risk of the machine tipping over and injuring persons or being damaged itself during movement and set up. Tilt resistance is guaranteed up to an angle of 10° (according to IEC 60974-1).

- Set up and transport the machine on level, solid ground.
- Secure add-on parts using suitable equipment.

**Risk of accidents due to incorrectly installed leads!**

Incorrectly installed leads (mains, control and welding leads or intermediate hose packages) can present a tripping hazard.

- Lay the supply lines flat on the floor (avoid loops).
- Avoid laying the leads on passage ways.

**Risk of injury from heated coolant and its connections!**

The coolant used and its connection or connection points can heat up significantly during operation (water-cooled version). When opening the coolant circuit, escaping coolant may cause scalding.

- Open the coolant circuit only when the power source or cooling unit is switched off!
- Wear proper protective equipment (protective gloves)!
- Seal open connections of the hose leads with suitable plugs.



***The units are designed for operation in an upright position!***

***Operation in non-permissible positions can cause equipment damage.***

- ***Only transport and operate in an upright position!***



***Accessory components and the power source itself can be damaged by incorrect connection!***

- ***Only insert and lock accessory components into the relevant connection socket when the machine is switched off.***
- ***Comprehensive descriptions can be found in the operating instructions for the relevant accessory components.***
- ***Accessory components are detected automatically after the power source is switched on.***



***Protective dust caps protect the connection sockets and therefore the machine against dirt and damage.***

- ***The protective dust cap must be fitted if there is no accessory component being operated on that connection.***
- ***The cap must be replaced if faulty or if lost!***

## 3 Intended use

### **WARNING**



#### **Hazards due to improper usage!**

The machine has been constructed to the state of the art and any regulations and standards applicable for use in industry and trade. It may only be used for the welding procedures indicated at the rating plate. Hazards may arise for persons, animals and material objects if the equipment is not used correctly. **No liability is accepted for any damages arising from improper usage!**

- The equipment must only be used in line with its designated purpose and by trained or expert personnel!
- Do not improperly modify or convert the equipment!

### 3.1 Applications

Fume extraction torch for arc welding machines

### 3.2 Documents which also apply

#### 3.2.1 Warranty

For more information refer to the "Warranty registration" brochure supplied and our information regarding warranty, maintenance and testing at [www.ewm-group.com](http://www.ewm-group.com)!

#### 3.2.2 Declaration of Conformity



This product corresponds in its design and construction to the EU directives listed in the declaration. The product comes with a relevant declaration of conformity in the original.

The manufacturer recommends carrying out the safety inspection according to national and international standards and guidelines every 12 months (from commissioning).

#### 3.2.3 Service documents (spare parts)

### **WARNING**



#### **No improper repairs and modifications!**

**To prevent injuries and damage to the machine, only competent personnel (authorised service personnel) are allowed to repair or modify the machine.**

**Unauthorised manipulations will invalidate the warranty!**

- Instruct competent personnel (authorised service personnel) to repair the machine.

Spare parts can be obtained from the relevant authorised dealer.

### 3.2.4 Part of the complete documentation

This document is part of the complete documentation and valid only in combination with all other parts of these instructions! Read and observe the operating instructions for all system components, especially the safety instructions!

The illustration shows a general example of a welding system.

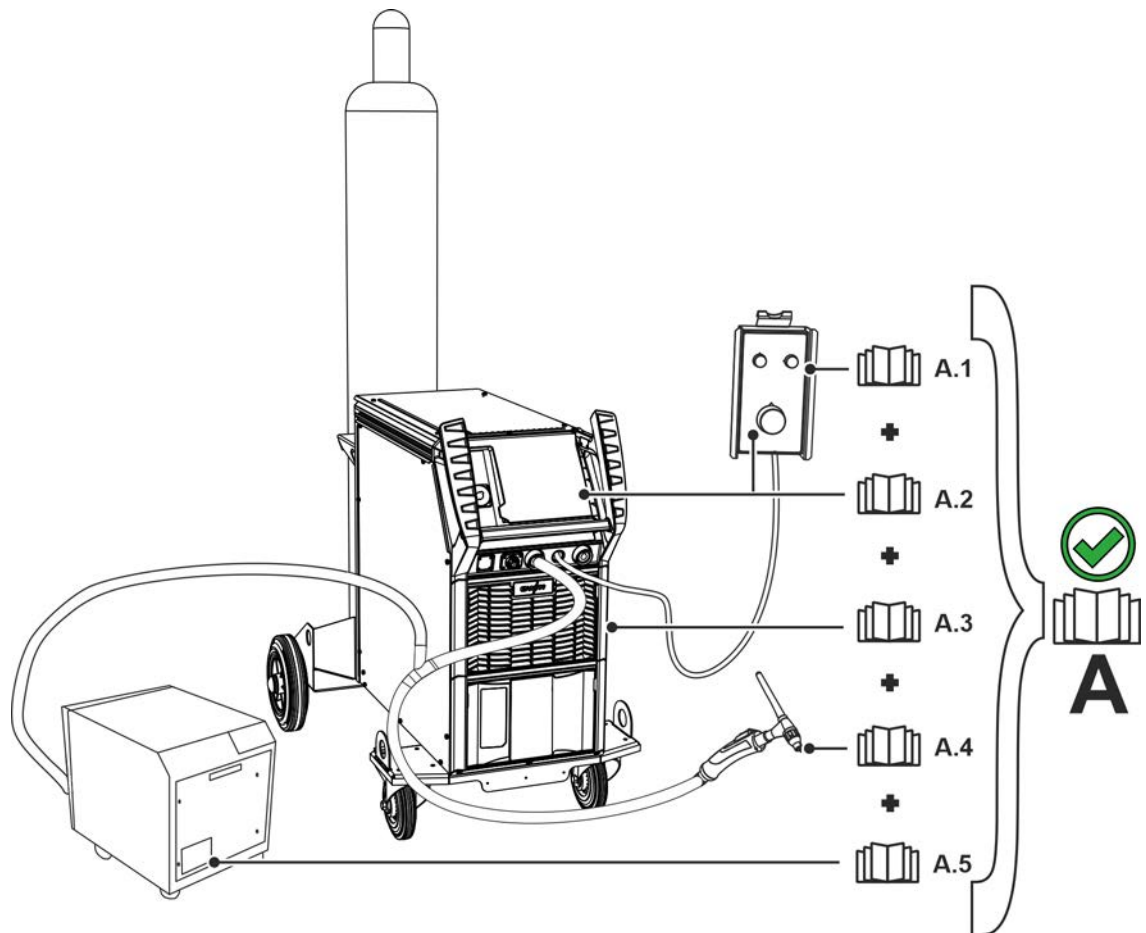

Figure 3-1

The illustration shows a general example of a welding system.

Item	Documentation
A.1	Remote control
A.2	Control
A.3	Power source
A.4	Welding torch
A.5	Welding fume extraction and filter system
A	Overall documentation

## 4 Product description – quick reference

### 4.1 Product variants

Version	Functions	Rated output
GD	<b>Gas-cooled with decentral connection</b>	TIG 150
5P	<b>Double push-button control</b> The welding power (welding current) can be reduced to the secondary current during the welding process.	TIG 150
U/D 8P	<b>Control Up-/Down</b> The welding power (welding current) and pre-selected parameters can be infinitely increased or decreased during the welding process.	TIG 150
F1	<b>Fume extraction torch</b> The welding torch is designed to extract welding fumes and is equipped with a ball joint.	TIG 150

## 4.2 Welding fume extractor

### 4.2.1 TIG 150 F1 GD

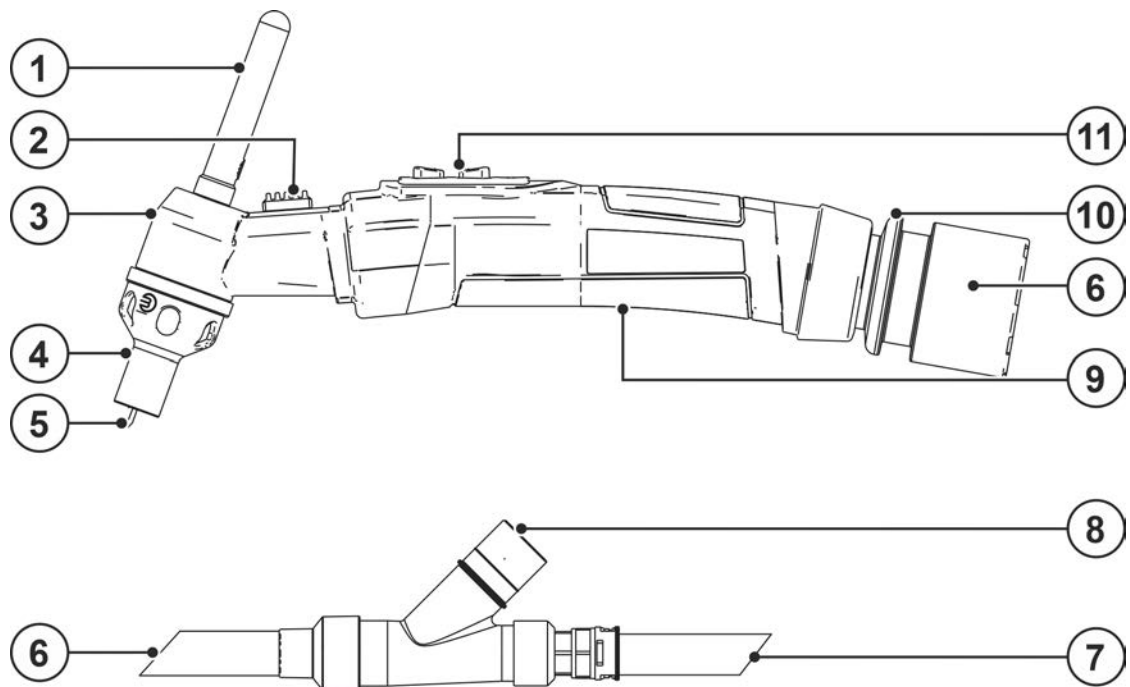

Figure 4-1

Item	Symbol	Description
1		Back cap
2		Bypass slider, extraction capacity
3		Torch body
4		Extraction nozzle with integrated gas nozzle
5		Tungsten electrode
6		Welding torch hose package
7		Connection variants > see 4.2.1.1 chapter
8		Connection, extraction unit Connect to extraction device or central extraction unit Ø = 42.5 mm
9		Grip plate
10		Ball joint
11		Operating elements > see 5.5.2 chapter

## 4.2.1.1 Connection variants

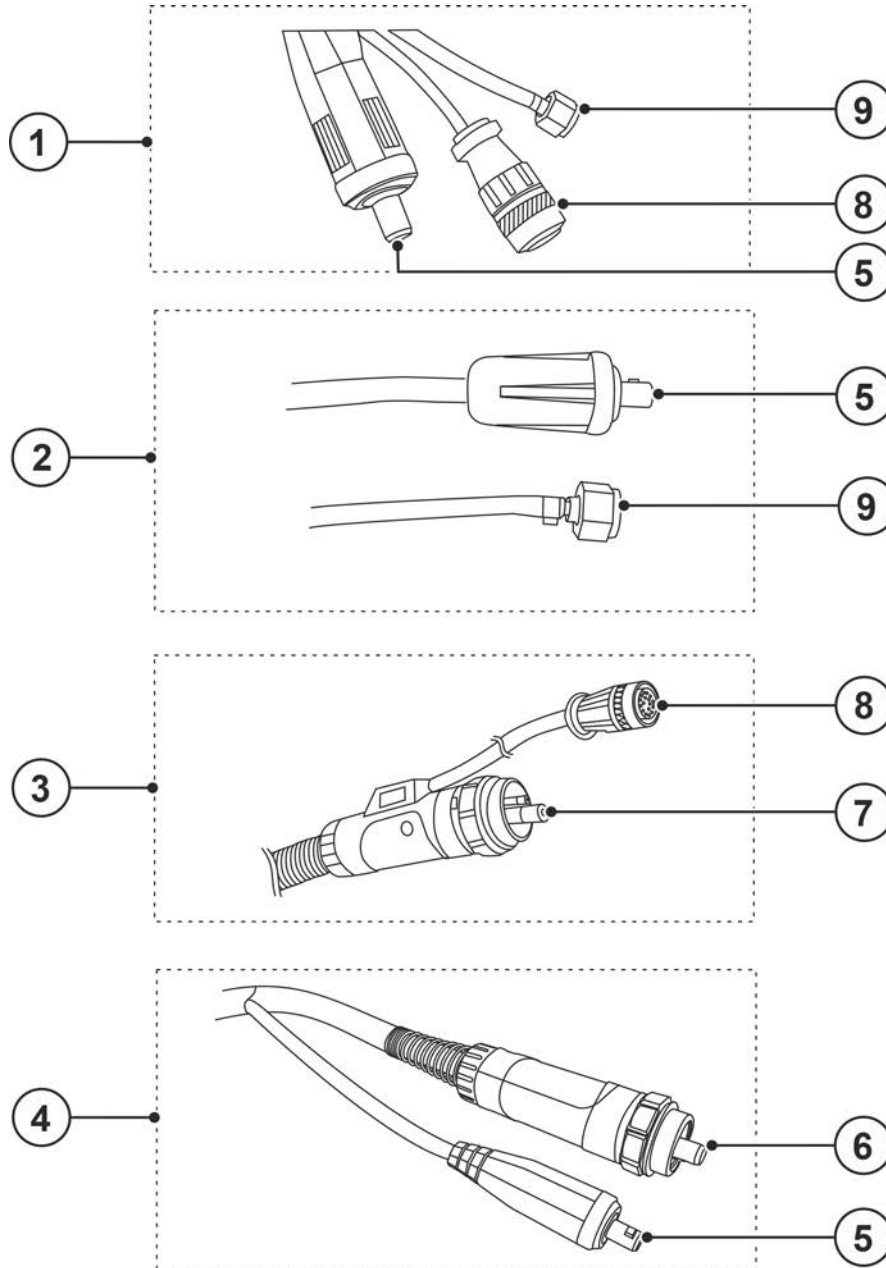



Figure 4-2

Item	Symbol	Description
1		<b>Decentral connection (standard)</b> Decentral welding current
2		<b>Decentral connection – rotary gas valve</b> Decentral welding current, rotary gas valve
3		<b>Euro central connection</b> Welding current and shielding included.
4		<b>Euro torch connector – combination</b> Shielding gas integrated, decentral welding current
5		<b>Welding current connection</b> Decentral
6		<b>Euro torch connector</b> Shielding gas integrated.



Item	Symbol	Description
7		<b>Euro central connection</b> Welding current and shielding included.
8		<b>Control lead cable plug</b>
9		<b>Shielding gas hose</b> Crown nut G 1/4"

## 5 Design and function

### 5.1 General

#### **WARNING**



**Risk of injury from electrical voltage!**

**Contact with live parts, e.g. power connections, can be fatal!**

- Observe the safety information on the first pages of the operating instructions!
- Commissioning must be carried out by persons who are specifically trained in handling power sources!
- Connect connection or power cables while the machine is switched off!

#### **CAUTION**



**Risk of injury due to moving parts!**

**The wire feeders are equipped with moving parts, which can trap hands, hair, clothing or tools and thus injure persons!**

- Do not reach into rotating or moving parts or drive components!
- Keep casing covers or protective caps closed during operation!



**Risk of injury due to welding wire escaping in an unpredictable manner!**

**Welding wire can be conveyed at very high speeds and, if conveyed incorrectly, may escape in an uncontrolled manner and injure persons!**

- Before mains connection, set up the complete wire guide system from the wire spool to the welding torch!
- Check wire guide at regular intervals!
- Keep all casing covers or protective caps closed during operation!



**To prevent damage to the fume extraction torch, never operate it without the extraction nozzle.**



**Accessory components and the power source itself can be damaged by incorrect connection!**

- **Only insert and lock accessory components into the relevant connection socket when the machine is switched off.**
- **Comprehensive descriptions can be found in the operating instructions for the relevant accessory components.**
- **Accessory components are detected automatically after the power source is switched on.**



**Protective dust caps protect the connection sockets and therefore the machine against dirt and damage.**

- **The protective dust cap must be fitted if there is no accessory component being operated on that connection.**
- **The cap must be replaced if faulty or if lost!**

**Read and observe the documentation to all system and accessory components!**

## 5.2 Scope of delivery

The delivery is checked and packaged carefully before dispatch, however it is not possible to exclude the possibility of damage during transit.

### Receiving inspection

- Check that the delivery is complete using the delivery note!

### In the event of damage to the packaging

- Check the delivery for damage (visual inspection)!

### In the event of complaints

If the delivery has been damaged during transport:

- Please contact the last haulier immediately!
- Keep the packaging (for possible checking by the haulier or for the return shipment).

### Packaging for returns

If possible, please use the original packaging and the original packaging material. If you have any queries on packaging and protection during transport, please contact your supplier.

## 5.3 Transport and installation

### CAUTION



**Risk of accidents due to supply lines!**

**During transport, attached supply lines (mains leads, control cables, etc.) can cause risks, e.g. by causing connected machines to tip over and injure persons!**

- Disconnect all supply lines before transport!

### 5.3.1 Ambient conditions



***Equipment damage due to contamination!***

***Unusually high amounts of dust, acids, corrosive gases or substances can damage the machine (observe maintenance intervals > see 7.1.4 chapter).***

- ***Avoid large amounts of smoke, steam, oily fumes, grinding dust and corrosive ambient air!***

#### In operation

Temperature range of the ambient air:

- -10 °C to +40 °C (-13 F to 104 F) <sup>[1]</sup>

Relative humidity:

- up to 50 % at 40 °C (104 F)
- up to 90 % at 20 °C (68 F)

#### Transport and storage

Storage in a closed area, temperature range of the ambient air:

- -25 °C to +55 °C (-13 F to 131 F) <sup>[1]</sup>

Relative humidity

- up to 90 % at 20 °C (68 F)

<sup>[1]</sup> Ambient temperature dependent on coolant! Observe the coolant temperature range of the torch cooling

### 5.4 Wear part replacement

#### 5.4.1 Deinstallation/Installation

When the welding quality deteriorates, the cause in most cases is worn electrodes and / or nozzles. To prevent damage to the welding torch, the replacement of wear parts must not be delayed unnecessarily.

**Before starting any work on the welding torch, the welding system must be switched off and secured against accidental re-start. All machine components must have cooled down.**

The threads of the wear parts are all right-hand threads:

- To loosen parts: turn anti-clockwise
- To mount parts: turn clockwise

**All screw and or plug connections can be made without tools.**

When changing wear parts, all individual components must always be checked for damage or wear and replaced if necessary. All part connections or sealing surfaces must be cleaned.

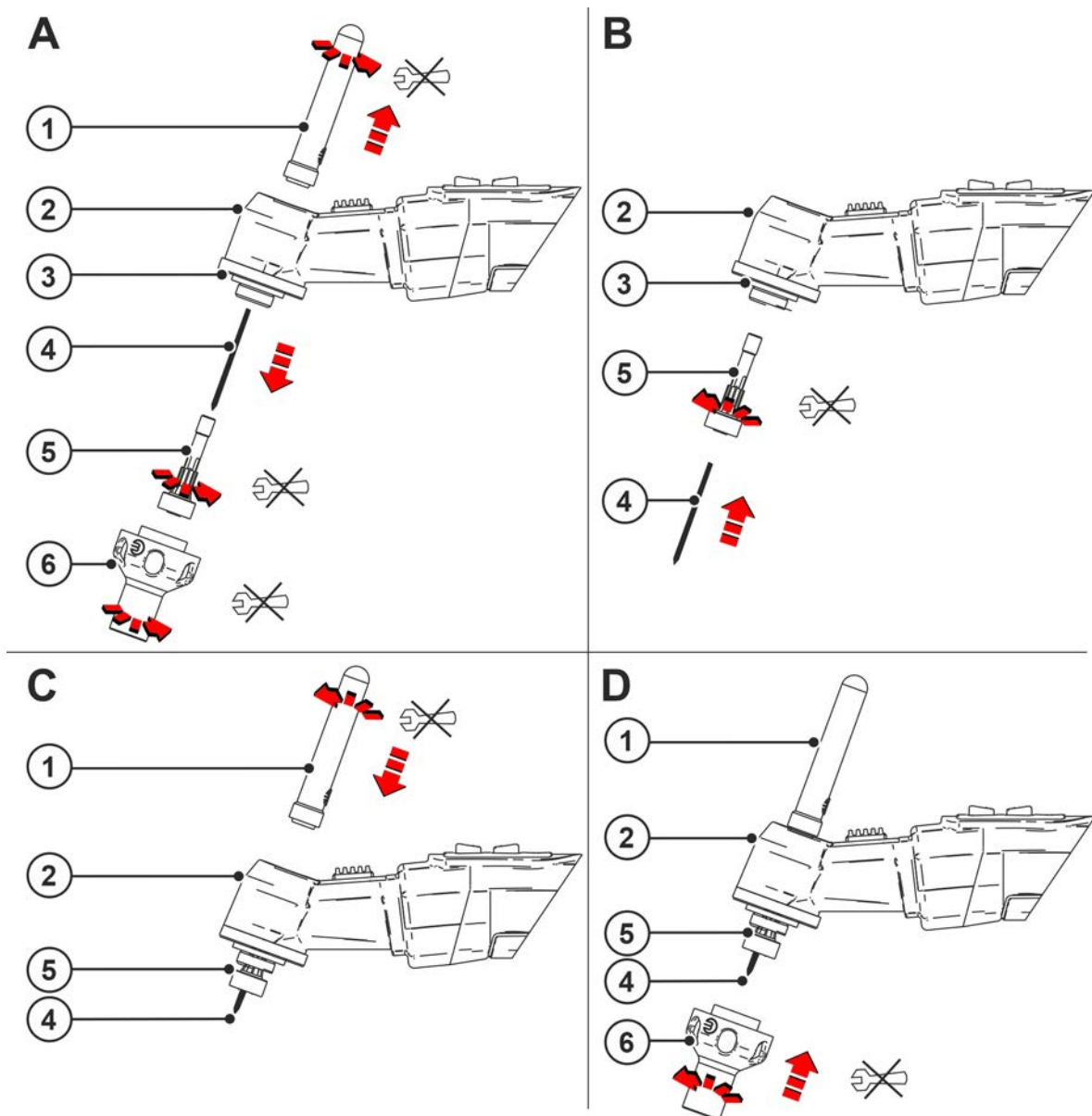

Figure 5-1

Item	Symbol	Description
1		Back cap
2		Torch body
3		Torch connection block
4		Tungsten electrode

Item	Symbol	Description
5		Gas diffuser
6		Extraction nozzle with integrated gas nozzle

- Unscrew and remove the extraction nozzle.
- Loosen back cap by hand.
- Pull out the tungsten electrode.
- Loosen gas diffuser by hand.
- To assemble, follow the steps for disassembly in reverse order.

**In place of the gas diffuser, an electrode holder can be used.**

**Screw on the corresponding back cap according to the length of the tungsten electrode.**

**In order to guarantee a decent welding result, ensure that both the tungsten electrode and the extraction nozzle are screwed firmly into place.**

## 5.4.2 Electrode replacement

**To prevent damage to the machine and incorrect welding results, the electrode gap must be adjusted each time the electrode is changed. The setting can be made using a commercially available calliper. Gas nozzle and electrode must be used in the appropriate combination.**

### 5.4.2.1 Regrinding the electrode

The electrode shape is decisive for a good welding result. Therefore, it is necessary to grind electrodes by machine to the correct shape before use. The electrode must be replaced if the electrode tip is excessively worn, tarnished too much or burned back asymmetrically. It is possible to regrind electrodes down to a minimum length of 42 mm. The regrinding of the electrode tip must be carried out by machine with a grinding angle of 30°.

**Note the grinding direction**

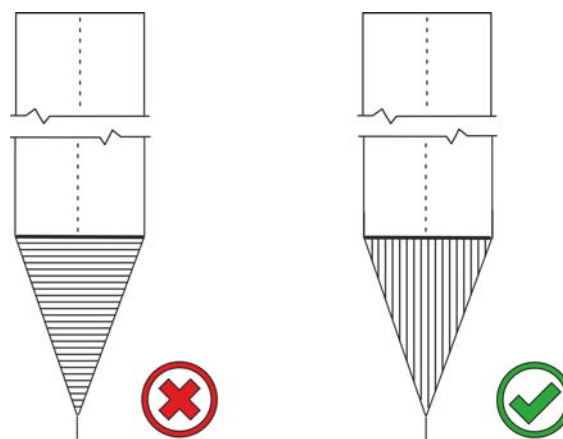

Figure 5-2

### Regrinding electrodes centrically

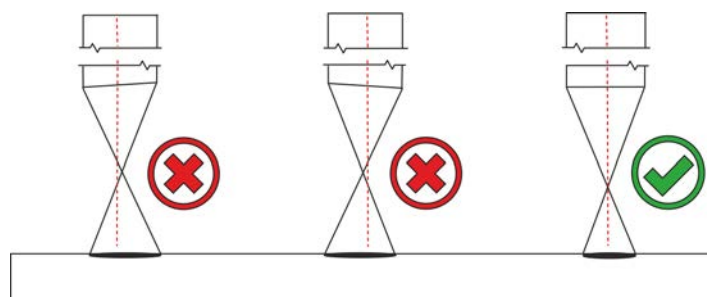

Figure 5-3

The tip of the electrode should be centred in the longitudinal axis of the electrode. In the case of deviations, there is a risk that the arc will become unstable. Especially in automated welding, a non-centred electrode tip leads to ignition next to the proper ignition point.

**Penetration above grinding angle**

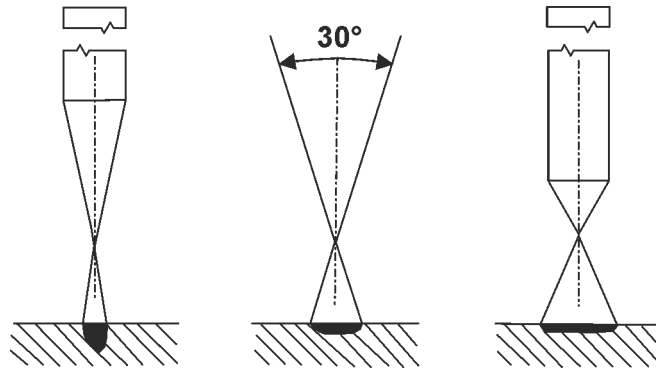

Figure 5-4

The more pointed the grinding cone, the deeper the penetration. The blunter the grinding cone, the shallower the penetration.

### 5.4.2.2 Setting the electrode spacing

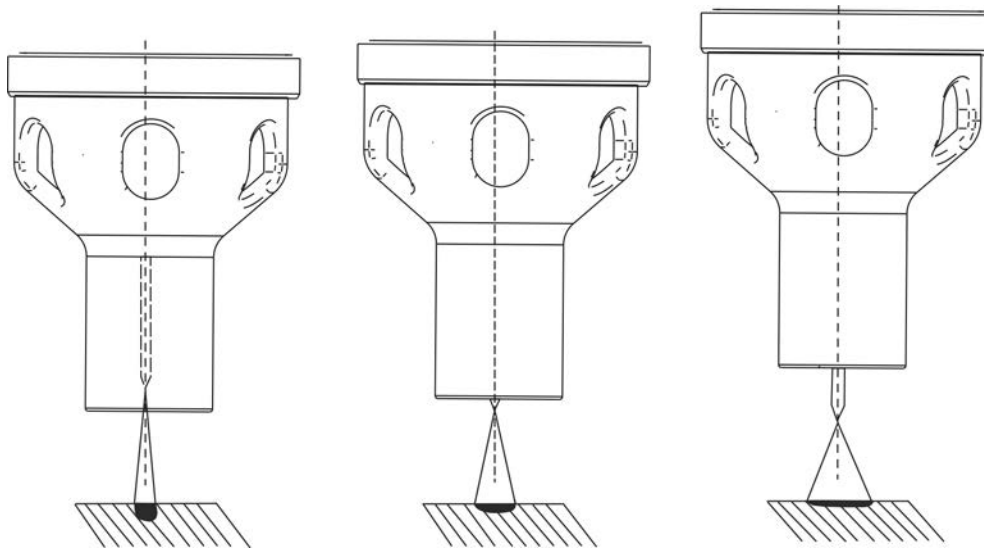

Figure 5-5

Make sure of the correct electrode gap!

## 5.5 Function specification

### 5.5.1 General

TIG welding torches are connected to the power source via the hose package. The following components are guided through the hose package:

- welding current lead
- shielding gas supply
- control cable and
- welding fume extraction hose.

With water-cooled TIG welding torches, the

- coolant supply and
- coolant return

are also guided through the hose package.

With TIG welding, the welding consumable is usually added manually in form of a stick. With fully automatic machines, the welding consumable is usually added as a wire by a separate wire feeder.

### 5.5.2 Operating elements

#### 5.5.2.1 Standard TIG torch (5-pole)

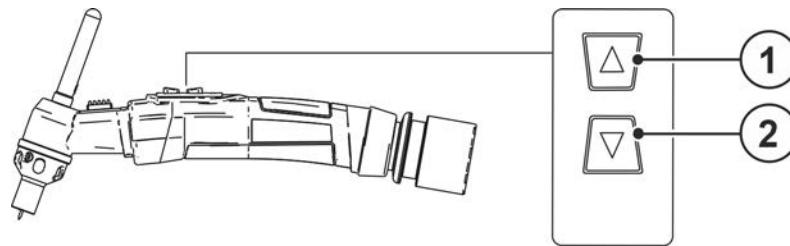

Figure 5-6

Item	Symbol	Description
1		<b>Torch trigger 1</b> Welding current ON/OFF
2		<b>Torch trigger 2</b> Welding current is reduced to secondary current.

TIG torches are equipped with a torch trigger. This trigger is used to:

- switch the welding current on and off,
- reduce the current during welding to a secondary current by tapping it.

Tapping function: Swiftly tap the torch trigger to change the function. The set torch mode determines the operating mode.

#### 5.5.2.2 TIG Up/Down torch

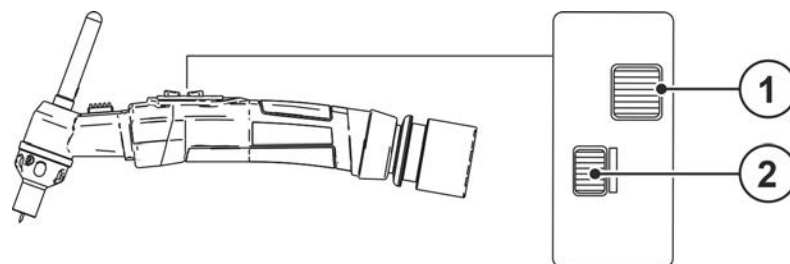

Figure 5-7

Item	Symbol	Description
1		<b>Torch trigger</b> Welding current ON/OFF

Item	Symbol	Description
2		<b>Torch trigger</b> Up/Down function

TIG Up/Down torches are equipped with two torch triggers. These triggers are used to:

- switch the welding current on and off,
- reduce the current to a secondary current by tapping it,
- infinitely increase the welding current during welding (UP function) or
- infinitely decrease the welding current (DOWN function).

Tapping function: Swiftly tap the torch trigger to change the function. The set torch mode determines the operating mode.



## 6 Commissioning

### 6.1 Hose package connection

Information on the connection of the torch hose package can be found in the corresponding operating instructions for the power source.

### 6.2 Welding fume extractor



**To prevent damage and to ensure full functionality of the fume extraction torch, comply with the points below:**

- **Observe the local occupational safety regulations.**
  - **Mount all fume extraction torch components in accordance with the regulations.**
  - **Prior to each use, connect the fume extraction torch to the extraction device or filter system and switch these on.**
  - **Check the extraction hoses for damage or soiling at regular intervals and no less than once a week.**
  - **Observe warning signals and indicators on the welding fume extraction unit. Replace saturated filters.**
  - **Additional hoses or hoses from other manufacturers can result in a drop in pressure of the fume extraction torch.**
- Connect the exhaust hoses of the exhaust and filter system.
  - Switch on the exhaust and filter system
  - Check the flow rate; too high of a flow rate can cause welding defects.

## 7 Maintenance, care and disposal

### 7.1 General

#### **DANGER**



**Risk of injury due to electrical voltage after switching off!**

**Working on an open machine can lead to fatal injuries!**

**Capacitors are loaded with electrical voltage during operation. Voltage remains present for up to four minutes after the mains plug is removed.**

1. Switch off machine.
2. Remove the mains plug.
3. Wait for at least 4 minutes until the capacitors have discharged!

#### **WARNING**



**Improper maintenance, testing and repairs!**

**Maintenance, testing and repair of the machine may only be carried out by skilled and qualified personnel (authorised service personnel). A competent person is someone who, based on training, knowledge and experience, can recognize the hazards and possible consequential damage that may occur when testing power sources and can take the necessary safety precautions.**

- Follow the maintenance instructions > see 7.1.4 chapter.
- If any of the test requirements below are not met, the unit must not be put back into operation until it has been repaired and tested again.

Repair and maintenance work may only be performed by qualified authorised personnel; otherwise the right to claim under warranty is void. In all service matters, always consult the dealer who supplied the machine. Return deliveries of defective equipment subject to warranty may only be made through your dealer. When replacing parts, use only original spare parts. When ordering spare parts, please quote the machine type, serial number and item number of the machine, as well as the type designation and item number of the spare part.

The welding torch is one of the most stressed components of the welding system. Due to the high thermal load and contamination, regular maintenance and care not only extends the service life of the system but also saves costs in the long term through the use of fewer replacement parts and less downtime. Perfect welding results can only be achieved with a properly maintained welding torch.

For maintenance and care, use only the tools, aids and tightening torques specified in the operating instructions.

#### 7.1.1 Identifying damage or worn components

Electrode holder/collet body

- Clinging weld spatter that can no longer be removed.
- Penetration or burn-off; damage to thread

Gas nozzle/extraction nozzle

- Clinging weld spatter, cracks or lack of fusion, damage to thread

Insulator

- Cracks, lack of fusion or burnt-off outer edges

Back cap

- Damage to thread, cracks or lack of fusion

Electrode

- Blunt, lack of fusion, burn-off

Torch neck

- Penetration or burn-off of insulation
- Cracks or lack of fusion of the insulation

## Torch connection

- The thread of the crown nut is dirty or damaged.
- For water-cooled welding torches, check the coolant connections for damage.

## Grip

- Cracks, penetration

## Hose package

- Cracks, penetration
- Clogged welding fume extraction hoses

## 7.1.2 Improper use

The illustration serves as an example only.

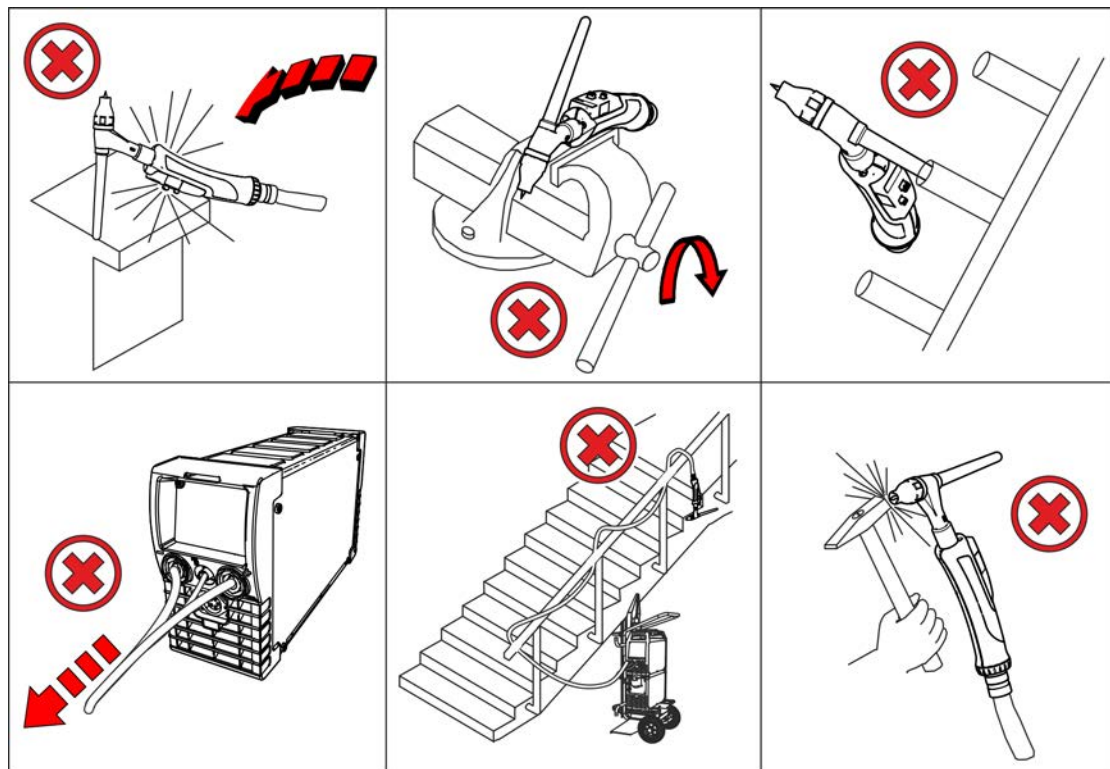

Figure 7-1



**To prevent damage and malfunction of the welding torch:**

- **Never hit hard objects (hammering)!**
- **Do not use the welding torch for levering or straightening!**
- **Do not bend the torch neck! Bending flexible torch necks is possible considering the maximum bending cycles.**
- **During breaks or after work, place the welding torch in the torch holder provided on the welding machine or at the workplace!**
- **Never throw the welding torch!**
- **Do not pull welding machines / wire feeders with the welding torch!**
- **Do not wind the hose package around the body and particularly the forearms!**

## 7.1.3 Maintenance and care before each use

- Loosen the gas nozzle/extraction nozzle; check the replacement parts for damage; replace, if necessary, and ensure a tight fit.
- Clean and remove soiling and welding spatter from the welding torch and, particularly, the wear parts; replace any worn or defective parts, if necessary.
- With water-cooled welding torches, check the coolant connections for tightness and flow. Check the coolant fill level at the cooling unit.
- Check the grip and hose package for cracks and damage.

## 7.1.4 Regular maintenance

The regular maintenance of a welding torch depends heavily on the duration of use and the stress and must be specified by the operator / owner. As a rule of thumb, every time the wire spool or wire basket is replaced or, if necessary, at a change of shift.

**The illustration serves as an example only.**

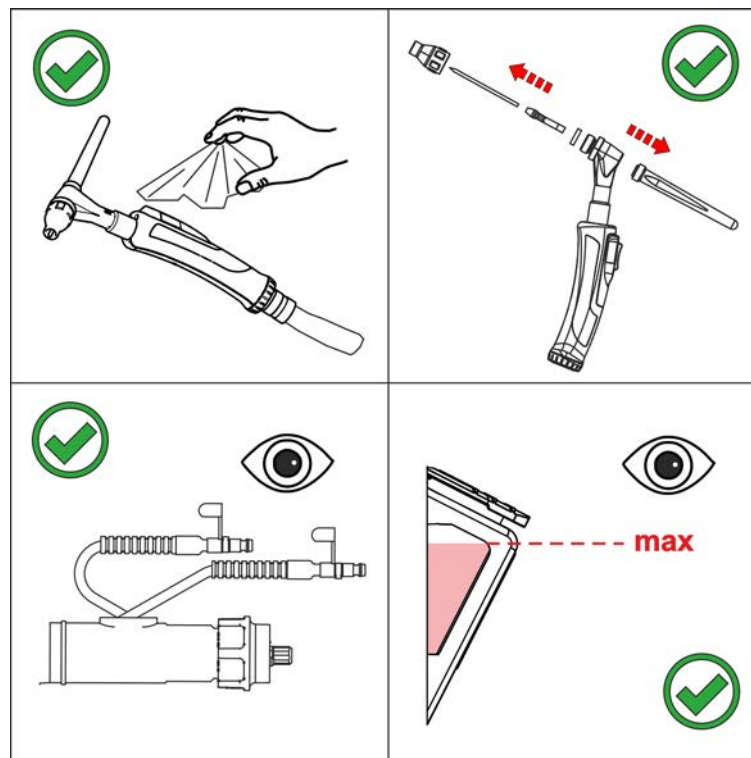

Figure 7-2

- Disconnect the welding torch from the machine, remove the replacement parts and blow out the wire duct and gas connection of the torch alternately with compressed air (max. 4 bar) free of oil and condensed water.
- Mount the replacement parts, connect the welding torch to the machine and purge twice with shielding gas (gas test).

## 7.1.5 Extraction unit

- Check the extraction hoses for damage or soiling at regular intervals and no less than once a week.
- Observe warning signals and indicators on the welding fume extractor. Replace saturated filters.

## 7.2 Disposing of equipment



### Proper disposal!

The machine contains valuable raw materials, which should be recycled, and electronic components, which must be disposed of.

- **Do not dispose of in household waste!**
- **Observe the local regulations regarding disposal!**
- According to European provisions (Directive 2012/19/EU on Waste of Electrical and Electronic Equipment), used electric and electronic equipment may no longer be placed in unsorted municipal waste. It must be collected separately. The symbol depicting a waste container on wheels indicates that the equipment must be collected separately.  
This machine has to be disposed of, or recycled, in accordance with the waste separation systems in use.

According to German law (law governing the distribution, taking back and environmentally correct disposal of electrical and electronic equipment (ElektroG)), used machines are to be placed in a collection system separate from unsorted municipal waste. The public waste management utilities (communities) have created collection points at which used equipment from private households can be disposed of free of charge.

The deletion of personal data is the responsibility of the end user.

Lamps, batteries or accumulators must be removed and disposed of separately before disposing of the device. The type of battery or accumulator and its composition is marked on the top (type CR2032 or SR44). The following EWM products may contain batteries or accumulators:

- **Welding helmets**  
Batteries or accumulators are easy to remove from the LED cassette.
- **Device controls**  
Batteries or accumulators are located on the back of these in corresponding sockets on the circuit board and are easy to remove. The controls can be removed using standard tools.

Information on returning used equipment or collections can be obtained from the respective municipal administration office. Devices can also be returned to EWM sales partners across Europe.

Further information on the topic of the disposal of electrical and electronic equipment can be found on our website at: <https://www.ewm-group.com/de/nachhaltigkeit.html>.

## 8 Rectifying faults

All products are subject to rigorous production checks and final checks. If, despite this, something fails to work at any time, please check the product using the following flowchart. If none of the fault rectification procedures described leads to the correct functioning of the product, please inform your authorised dealer.

### 8.1 Checklist for rectifying faults

**The correct machine equipment for the material and process gas in use is a fundamental requirement for perfect operation!**

Legend	Symbol	Description
	↗	Fault/Cause
	✘	Remedy

#### Welding torch overheated

- ↗ Loose welding current connections
  - ✘ Tighten power connections on the torch and/or on the workpiece
- ↗ Overload
  - ✘ Check and correct welding current setting
  - ✘ Use a more powerful welding torch

#### Functional error with the welding torch operating elements

- ↗ Connection problems
  - ✘ Make control lead connections and check that they are fitted correctly.

#### Unstable arc

- ↗ Unsuitable or worn welding torch equipment
- ↗ Material inclusions in the tungsten electrode due to contact with filler material or workpiece
  - ✘ Regrind or replace the tungsten electrode
- ↗ Incompatible parameter settings
  - ✘ Check settings and correct if necessary
- ↗ Metal vapour on the gas nozzle
  - ✘ Clean and change gas nozzle

#### Pore formation

- ↗ Inadequate or missing gas shielding
  - ✘ Check shielding gas setting and replace shielding gas cylinder if necessary
  - ✘ Shield welding site with protective screens (draughts affect the welding result)
  - ✘ Check the O-rings on the Euro torch connector and torch neck and replace them if necessary.
  - ✘ Reduce the welding fume extraction rate.
  - ✘ Depending on the application, reduce the welding fume flow rate using the bypass slider.
- ↗ Unsuitable or worn welding torch equipment
  - ✘ Check size of gas nozzle and replace if necessary
  - ✘ Check the O-ring on the Euro torch connector and if necessary replace.
  - ✘ Check the extraction nozzle for wear regularly and replace, if necessary.
- ↗ Condensation in the gas tube
  - ✘ Purge hose package with gas or replace
  - ✘ Check the O-rings on the Euro torch connector and torch neck and replace them if necessary.

- ✓ High welding fume load
  - ✘ Reduce the welding fume extraction rate.
  - ✘ Clean the welding torch.
  - ✘ If necessary, close the bypass slider on the welding torch.
  - ✘ Properly attach the extraction nozzle and extraction hose and check for leak-tightness.
  - ✘ The extraction nozzle openings must be free of deposits.
  - ✘ Ensure that the extraction system is switched on.
  - ✘ Check the extraction system filter and replace it if saturated.

## 9 Technical data

Performance specifications and guarantee only in connection with original spare and replacement parts!

### 9.1 TIG 150 F1 GD

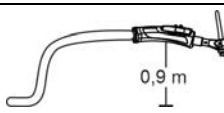
Welding torch polarity	Normally negative		
Guide type	Manually operated		
Voltage type	Direct voltage DC or Alternating voltage AC		
Shielding gas according to ISO 14175	Argon		
Duty cycle DC at 40° C <sup>[1]</sup>	35 %		
Maximum welding current Direct voltage	150 A		
Maximum welding current Alternating voltage	105 A		
Electrode types	Standard tungsten electrodes		
Electrode diameter	1,0 – 2,4 mm		
Switching voltage Push-button	0,02 - 42 V (DC and AC)		
Switching current Push-button	0,01 - 100 mA		
Switching capacity Push-button	max. 1 W		
Switching capacity Potentiometer	1 W at 40 °C		
Control Grip	42 V / 0,1 – 1 A		
max. Arc striking and voltage rating 50 Hz	10 kV		
Hose package length	4 m	8 m	12 m
Flow rate Connector $Q_{vc}$ <sup>[2]</sup>	28,9 m <sup>3</sup> /h	29,5 m <sup>3</sup> /h	26,1 m <sup>3</sup> /h
Flow rate Nozzle $Q_{vn}$ <sup>[2]</sup>	14,8 m <sup>3</sup> /h	14,8 m <sup>3</sup> /h	14,8 m <sup>3</sup> /h
Low pressure Connector $\Delta_{pc}$ <sup>[2] [3]</sup>	6,5 kPa	8,4 kPa	7,0 kPa
Ambient temperature	-10 °C to + 40 °C		
Voltage measurement	113 V (Peak value)		
Protection classification for the machine connections (EN 60529)	IP3X		
Gas flow	5 - 12 l/min		
Hose package length	4-, 8-, 12 m		
Connection	Decentralised connection		
Operating weight 	1,05 kg		
Standards used	See declaration of conformity (appliance documents)		
Test mark	CE / ENEC / UKCA		

<sup>[1]</sup> Load cycle: 10 min. (60 % DC  $\pm$  6 min. welding, 4 min. pause)

<sup>[2]</sup> > see 9.1.1 chapter

<sup>[3]</sup> Reference altitude sea level (SL) > see 13.1 chapter



### 9.1.1 Definition of terms

The illustration serves as an example only.

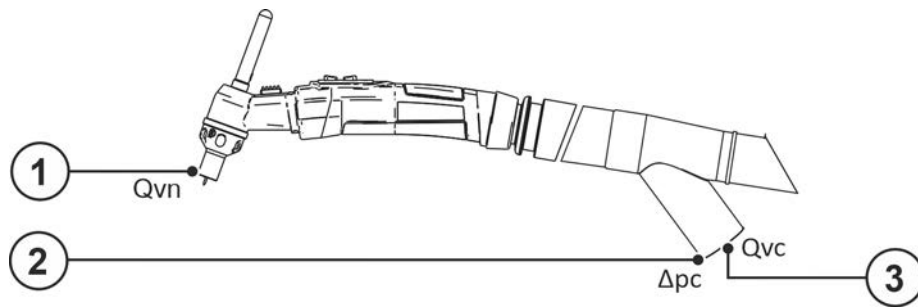

Figure 9-1

Item	Symbol	Description
1	$Q_{vn}$	Flow-rate nozzle
2	$\Delta_{pc}$	Vacuum connector
3	$Q_{vc}$	Flow rate connector

## 10 Accessories

Performance-dependent accessories like torches, workpiece leads, electrode holders or intermediate hose packages are available from your authorised dealer.

### 10.1 List of tools

Type	Designation	Item no.
O-Ring Picker	O-ring picker	098-005149-00000

### 10.2 Options

Type	Designation	Item no.
ON AA NW44	Adapter for welding fume extraction torch to connect to extraction hose Ø 44 mm	094-026782-00000
ON AA NW51	Adapter for welding fume extraction torch to connect to extraction hose Ø 51 mm	094-026788-00000

# 11 Replaceable parts

## 11.1 TIG 150 F1 GD



**The manufacturer's warranty becomes void if non-genuine parts are used!**

- Only use system components and options (power sources, welding torches, electrode holders, remote controls, spare parts and replacement parts, etc.) from our range of products!
- Only insert and lock accessory components into the relevant connection socket when the machine is switched off.

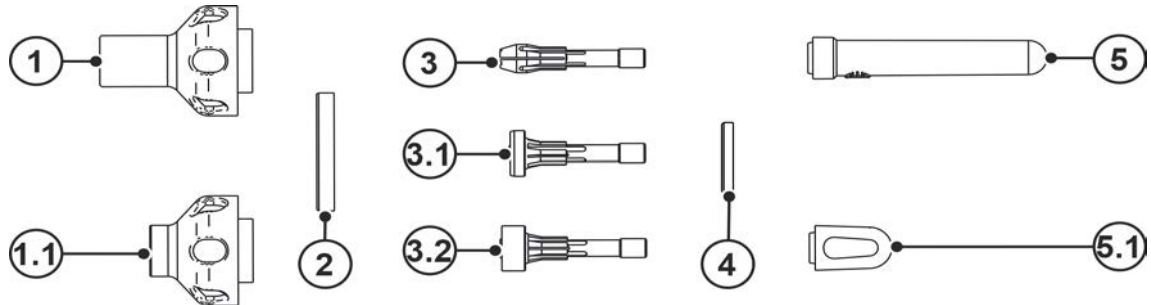

Figure 11-1

Item	Order number	Type	Designation
1	394-018963-00000	GN TIG 150/260 F1 8x37mm	Gas nozzle, ceramic
1	394-018964-00000	GN TIG 150/260 F1 9.5x37mm	Gas nozzle, ceramic
1	394-018965-00000	GN TIG 150/260 F1 12x37mm	Gas nozzle, ceramic
1.1	394-018960-00000	GN TIG 150/260 F1 8x25mm	Gas nozzle, ceramic
1.1	394-018961-00000	GN TIG 150/260 F1 9.5x25mm	Gas nozzle, ceramic
1.1	394-018962-00000	GN TIG 150/260 F1 12x25mm	Gas nozzle, ceramic
2	394-018966-00000	IR TIG F1	Insulation ring
3	094-012665-00000	COL 150/260 D=1.0MM	Electrode holder
3	094-012406-00000	COL 150/260 D=1.6MM	Electrode holder
3	094-012666-00000	COL 150/260 D=2.0MM	Electrode holder
3	094-011755-00000	COL 150/260 D=2.4MM	Electrode holder
3	094-012667-00000	COL 150/260 D=3.2MM	Electrode holder
3.1	094-012668-00000	COL DIF 150/260 D=1.0MM	Gas diffuser
3.1	094-012669-00000	COL DIF 150/260 D=1.6MM	Gas diffuser
3.1	094-012670-00000	COL DIF 150/260 D=2.0MM	Gas diffuser
3.1	094-011984-00000	COL DIF 150/260 D=2.4MM	Gas diffuser
3.1	094-012671-00000	COL DIF 150/260 D=3.2MM	Gas diffuser
3.2	094-023030-00000	CDIF TIG 150/260 Multilayer 1.0 mm	Gas diffuser, multi-layer
3.2	394-002357-00000	CDIF TIG 150/260 Multilayer 1.6 mm	Gas diffuser, multi-layer
3.2	094-023032-00000	CDIF TIG 150/260 Multilayer 2.0 mm	Gas diffuser, multi-layer
3.2	394-002038-00000	CDIF TIG 150/260 Multilayer 2.4 mm	Gas diffuser, multi-layer
3.2	394-002358-00000	CDIF TIG 150/260 Multilayer 3.2 mm	Gas diffuser, multi-layer
4	094-011979-00000	ISO TIG 150/260	Insulation ring
5	094-011753-00000	TCM TIG 150/260	Back cap, medium
5.1	094-011752-00000	TCS TIG 150/260	Back cap, short

## 12 Service documents

### 12.1 Circuit diagram

The circuit diagrams are only intended for authorised service personnel!

#### 12.1.1 Standard, up/down torches

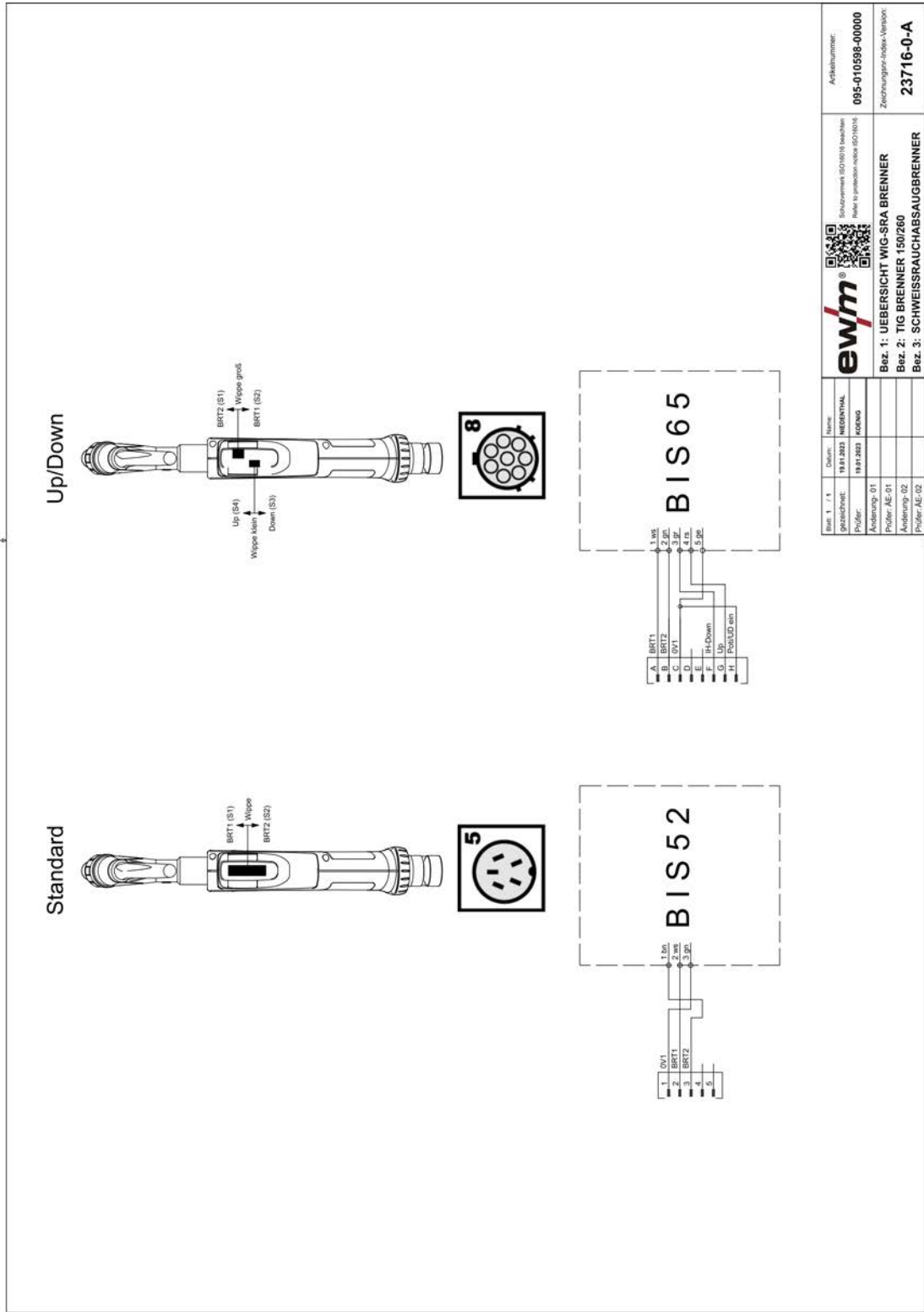

Blatt: 1 / 1	Zeichn. Name	Artikelnummer:
gezeichnet: 19.01.2023	NEUBRÜHNAL	095-010598-0000
geprüft: 19.01.2023	KORNG	Zeichnungsindeks-Version:
Änderung: 01		23716-0-A
Prüfer: AE-01		
Änderung: 02		
Prüfer: AE-02		

Schutzmarke ISO 9001 bescheinigt  
Referenz zu positionen index ISO 10106

Bez. 1: UEBERSICHT WIG-SRA BRENNER  
Bez. 2: TIC BRENNER 150/260  
Bez. 3: SCHWEISSRAUCHABSaugBRENNER

## 13 Appendix

### 13.1 Altitude alignment

The higher the altitude, the less vacuum is required at the connection piece  $\Delta p_c$  of the welding torch to achieve the required welding fume flow rate at the welding nozzle. Determine the corresponding factor in the following table:

$$P_{c \text{ user}}(Z) = f \times \Delta p_c$$

Explanation:

$P_{c \text{ user}}(Z)$	Required vacuum connector
f	Factor (determined in the following table)
$\Delta p_c$	Vacuum connector > see 9 chapter

Altitude Z in (m)	Factor f
0	1.00
250	0.97
500	0.94
750	0.91
1000	0.89
1250	0.86
1500	0.83
1750	0.81
2000	0.78
2250	0.76
2500	0.74

## 13.2 Searching for a dealer

Sales & service partners  
[www.ewm-group.com/en/specialist-dealers](http://www.ewm-group.com/en/specialist-dealers)



"More than 400 EWM sales partners worldwide"